



DISTRIBUTED BY



1-800-361-5361

# Alfa Laval Unique Mixproof CIP

## Double Seat valves

### Introduction

The Alfa Laval Unique Mixproof CIP valve is a double block-and-bleed valve that enables the simultaneous flow of two fluids through the same valve without the risk of cross-contamination. Purpose-built for routing cleaning media, this versatile, lightweight CIP valve safely directs CIP media. The Unique Mixproof CIP can distribute pressurized CIP media toward the area that requires cleaning or direct cleaning media through the top of a tank cleaning device into the tank. Based on the proven Unique Single Seat valves, it easily adapts to process requirements while meeting hygiene standards.

### Applications

The Alfa Laval Unique Mixproof CIP provides continuous flow management and CIP safety towards hygienic processes where product safety is high on the agenda, such as in the dairy, food, beverage, and many other industries.

### Benefits

- Get the product safety you need by eliminating the risk of cross-contamination
- Enhance the reliability and flexibility of your process and CIP setup when operating
- Minimize the risk of unplanned downtime and time and resources spent on routine maintenance
- Improve sustainability and limit environmental impact by reducing water and CIP media use
- Lower the total cost of ownership with a proven, cost-efficient mixproof valve for routing cleaning media

### Standard design

A series of base components, including a valve body, seals, a maintenance-free actuator, and an optimized plug design to minimize spillage, comprises the Alfa Laval Unique Mixproof CIP valve. Leakage detection holes enable visual inspection without requiring valve disassembly, alerting operators of the need for wear parts replacement.

Few straightforward, moveable parts contribute to reliable operation and reduced maintenance costs. The valve can also be fitted with Alfa Laval ThinkTop units.



### Working principle

The Alfa Laval Unique Mixproof CIP valve is a normally closed (NC) valve controlled remotely using compressed air. The valve has two independent plugs and a three-seal design to separate the two media from each other; the space between the seals forms a leakage chamber at atmospheric pressure under all operating conditions. Leakage rarely occurs, but if it should, the fluid flows into the leakage chamber and drains at the outlet for easy detection. When the valve is open, the leakage chamber is closed. The fluid then flows from one line to the other. The valve's three-seal design minimizes spillage and ensures the water and CIP media pass through and flush the leakage chamber.

The valve primarily handles cleaning media. Its balanced design ensures complete flow control and eliminates water hammer. Mounting upside down is possible.

## TECHNICAL DATA

### Pressure

Max. product pressure:	1000 kPa (10 bar) / 145 PSI
Min. product pressure:	Full Vacuum
Holding pressure (lower plug):	600 kPa (6 bar) / 87 PSI
Air pressure range:	600-800 kPa (6-8 bar) / 87-116 PSI

### Temperature

Temperature range:	EPDM -5 °C to +140 °C / 23 °F to 284 °F
--------------------	--

## PHYSICAL DATA

### Materials

Product-wetted steel parts	1.4404 (316L)
Other steel parts:	1.4301 (304)

### Surface finish

External (semi-bright):	Ra < 1.6 µm / Ra < 64 µi
Internal (polished):	Ra < 0.8 µm / Ra < 32 µi



**Note!** The Ra values are only for the internal surface.

### Product wetted seals

Sealing material:	EPDM, FPM, HNBR
-------------------	-----------------

### Other Seals

Actuator seals:	NBR
Guide Strip:	PTFE

## Valve body combination



11



12



21



22



20



30

### Valve body combinations, example: type 11

1 Number of ports - lower valve body

1 Number of ports - upper valve body



**Note!**

Standard: Inter-body clamped

## Pressure drop/capacity diagrams

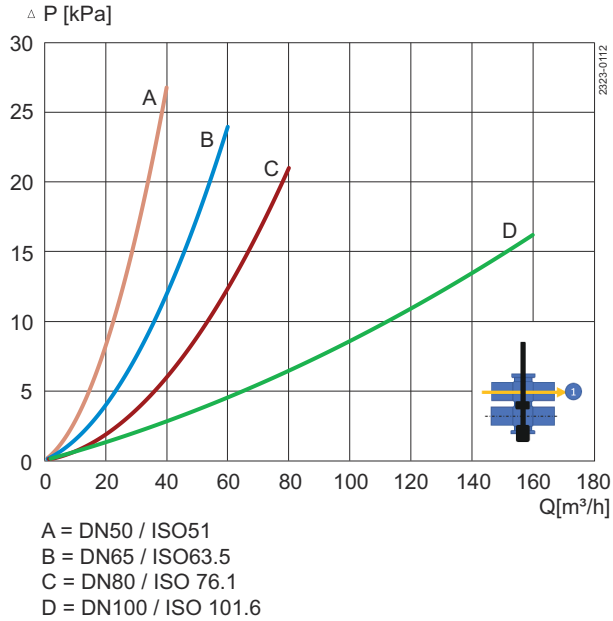

Figure 1. Pressure drop/capacity diagram, upper body

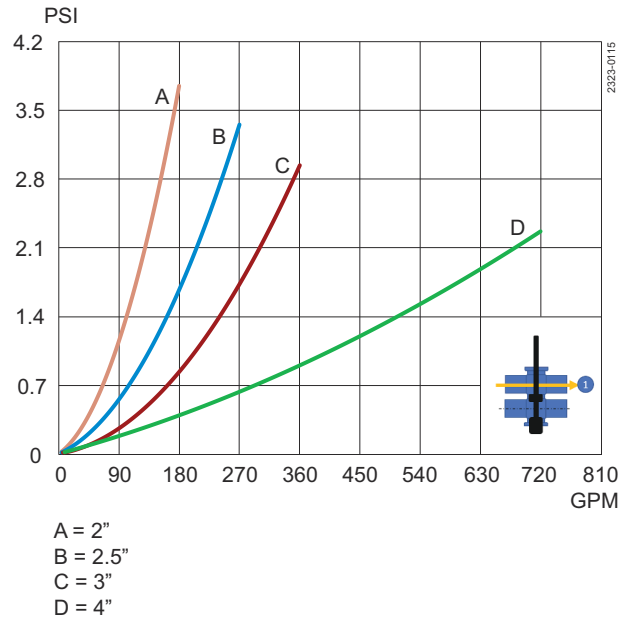

Figure 2. Pressure drop/capacity diagram, upper body

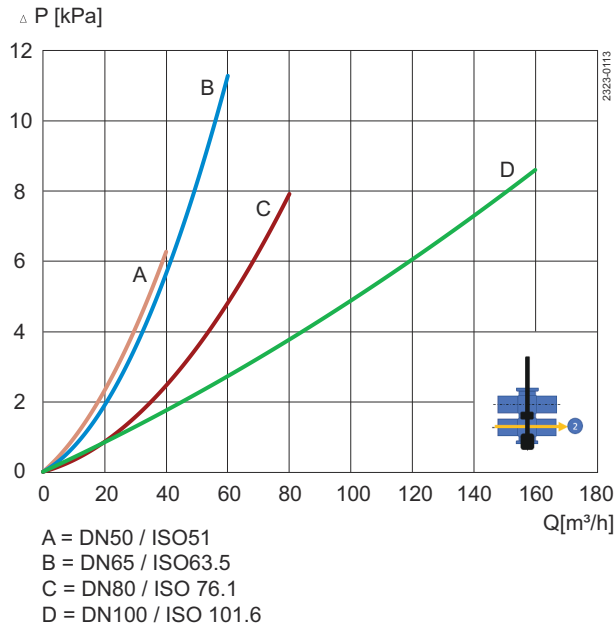

Figure 3. Pressure drop/capacity diagram, lower body

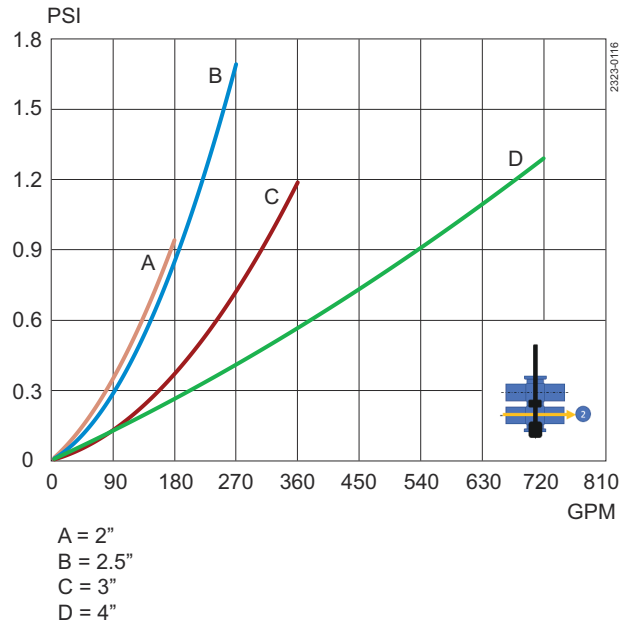

Figure 4. Pressure drop/capacity diagram, lower body

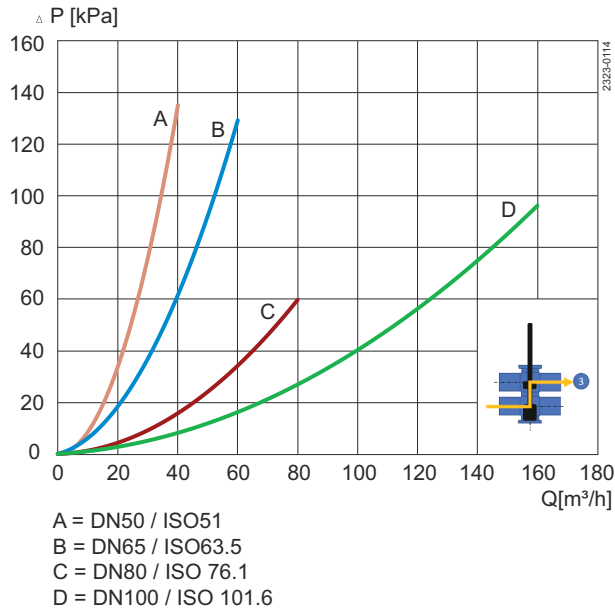

Figure 5. Pressure drop/capacity diagram, between bodies

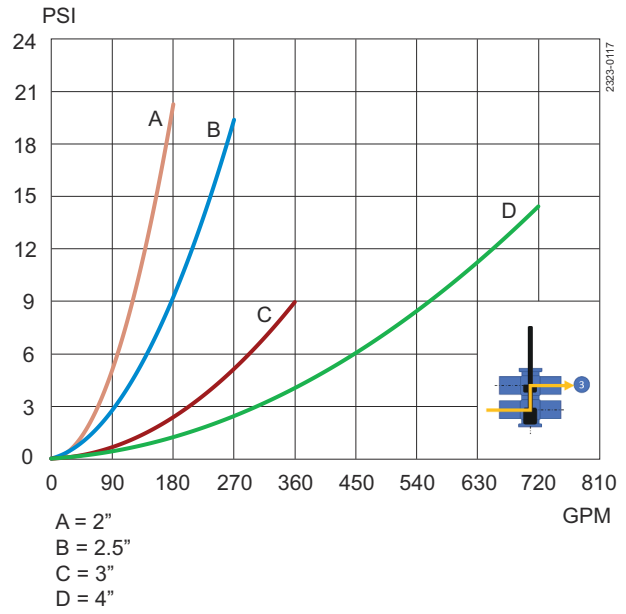

Figure 6. Pressure drop/capacity diagram, between bodies

### Air consumption

Size	DN/OD				DN			
ISO/DIN	51	63.5	76.1	101.6	50	65	80	100
Kv-value [m³/h]	34.4	52.2	104.3	163.3	34.4	52.2	104.3	163.3
Cv-value [gpm/psi]	39.8	60.4	120.5	188.8	39.8	60.4	120.5	188.8
<b>Airconsumption</b>								
Main Movement [n litre]	0.64	0.64	1.48	1.48	0.64	0.64	1.48	1.48
Main Movement [cubic inches]	38.84	38.84	90.48	90.48	38.84	38.84	90.48	90.48

### Dimensions

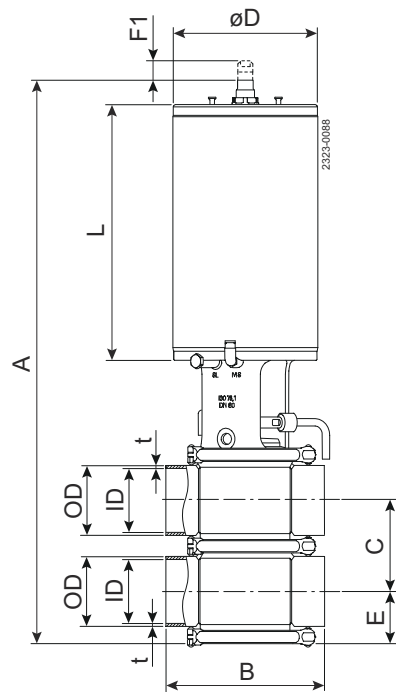

Figure 7. Unique Mixproof CIP

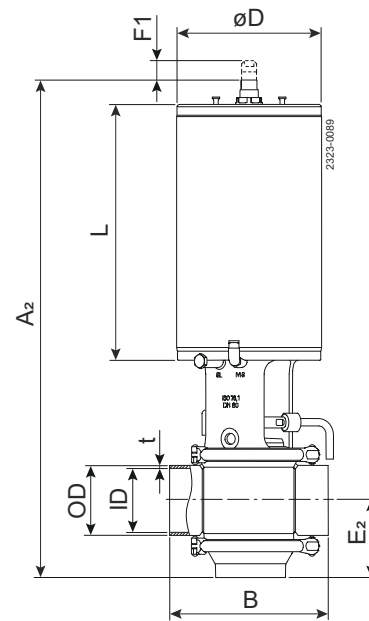

Figure 8. Unique Mixproof CIP Type 30

(mm)

Size	DN/OD				DN			
	51	63.5	76.1	101.6	50	65	80	100
A	471	496	612	661	476	508	628	666
A <sub>2</sub>	513	536	660	702	516	545	666	706
B	122	162	172	238	122	162	172	240
C	73.8	86.3	98.9	123.6	76	92	107	126
OD	51	63.5	76.1	101.6	53	70	85	104
ID	47.8	60.3	72.9	97.6	50	66	81	100
t	1.6	1.6	1.6	2	1.5	2	2	2
E	44	50	51	69	45	53	61	70
E <sub>2</sub>	85	90	99	110	85	90	99	110
F1	30.5	30.5	43	43	30.5	30.5	43	43
ØD	115	115	157	157	115	115	157	157
L	205	205	278	278	205	205	278	278
Weight, Type 22 (kg)	10.7	12.9	22.2	25.0	10.8	13.2	22.7	25.1
Weight, Type 30 (kg)	9.9	11.5	20.3	21.8	9.9	11.7	20.6	21.9

(inch)

Size	OD			
	2"	2½"	3"	4"
A	18.56	19.54	24.08	26.03
A <sub>2</sub>	20.20	21.10	25.98	27.64
B	4.80	6.38	6.77	9.37
C	2.91	3.40	3.89	4.87
OD	2.01	2.50	3.00	4.00
ID	1.88	2.37	2.87	3.84
t	0.06	0.06	0.06	0.08
E	1.71	1.98	2.00	2.72
E <sub>2</sub>	3.35	3.54	3.90	4.33
F1	1.20	1.20	1.69	1.69
ØD	4.54	4.54	6.20	6.20
L	8.06	8.06	10.94	10.93
Weight, Type 22 (lb)	23.6	28.4	49.0	55.1
Weight, Type 30 (lb)	21.8	25.4	44.8	48.1

DISTRIBUTED BY  
  
ENTERPRISES LTD.  
1-800-361-5361

This document and its contents are subject to copyrights and other intellectual property rights owned by Alfa Laval AB (publ) or any of its affiliates (jointly "Alfa Laval"). No part of this document may be copied, re-produced or transmitted in any form or by any means, or for any purpose, without Alfa Laval's prior express written permission. Information and services provided in this document are made as a benefit and service to the user, and no representations or warranties are made about the accuracy or suitability of this information and these services for any purpose. All rights are reserved.

200008486-2-EN-US

© Alfa Laval Corporate

#### How to contact Alfa Laval

Up-to-date Alfa Laval contact details for all countries are always available on our website at [www.alfalaval.com](http://www.alfalaval.com)