

ADU Sanitary Drum Unloading System

Highly Efficient, Gentle and Cost-effective

Unload drums quickly and easily with up to 99% or better product removal when you use the ADU from Ampco Applied Products. The ADU utilizes the Bornemann SLH-4G sanitary twin screw pump paired with an inflatable drum seal suction head that stays secured to the edge of the drum as it moves down unloading the contents. The SLH-4G and included cleaning module are fully CIP-able.

The ADU can unload a wide range of products with viscosities from 1-1,000,000cP with ease. The gentle conveyance and low pulsation operation of the SLH-4G maintains product integrity as the contents are emptied.

The ADU sanitary drum unloading system offers greater energy efficiency when compared to air driven units. The main system utilizes an electrically powered pumping system and controls, requiring only a small amount of air to lift/lower and seal the bladder to the drum.

Drums can be quickly positioned for unloading from the ground or from a pallet via the drum stops on the unloading deck and a v-block stop is available for pallets.

The ADU's sturdy modular design offers affordability and ease of maintenance.

DESIGN SPECIFICATIONS:

- 1-1,000,000 cP product
- Up to 30 gpm process
- 362 psi max discharge pressure
- CIP-able pumping rate 5-7 ft/sec

FEATURES:

- Over-pressurization monitoring
- Inflatable drum seal
- Pneumatic components are separate from electronic components
- Replaceable pneumatic cylinders
- Features the SLH-4G twin screw technology (3A certified)
- Made in the USA
- Low pulsation

AMPCO
APPLIED PRODUCTS



Inflatable Drum Seal

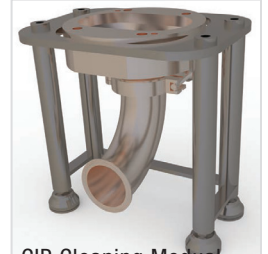

CIP Cleaning Module



Drum Stops



Electrical and Pneumatic Components Separated



V-block Backstop Optional

www.harcosupply.com

675 The Parkway,
Peterborough, Ontario K9J 7K2

800-361-5361
705-743-5361
sales@harco.on.ca

ADU Sanitary Drum Unloading System

DIMENSIONS: [millimeters] / inches

RAISED:

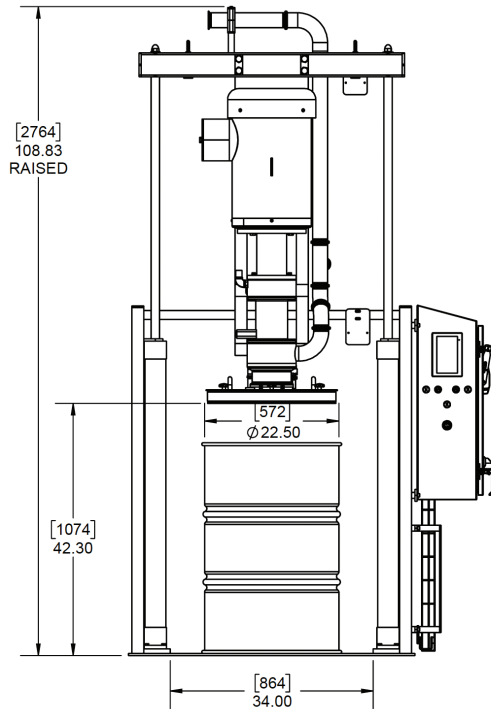

LOWERED:

DISCHARGE:
2.5" CLAMP CONNECTION

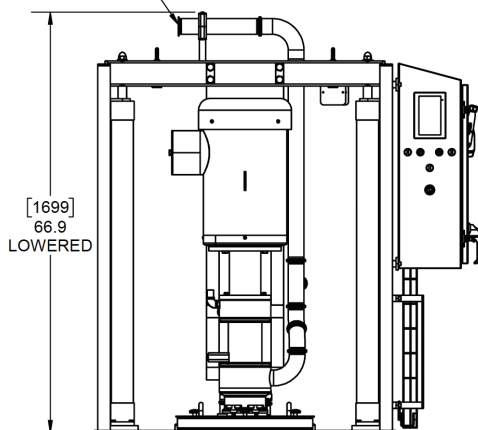

UTILITY REQUIREMENTS:

POWER SUPPLY:

- 460 V | 30 | 60HZ (standard)
- 230 V | 30 | 60HZ (optional)

AIR SUPPLY:

- 90 PSI (standard)

PUMP SEAL SPECIFICATIONS:

- Standard - Single Mechanical
- Optional - Double Mechanical seal (seal flush requires a water flow of 16oz/min)

TECHNICAL SPECIFICATIONS:

STANDARD CONTROLS:

- NEMA 4X enclosure
- 7" Touch screen display
- Inflatable follower plate
- Discharge pressure sensor

OPTIONAL CONTROLS:

- Allen Bradley controls
- EPDM static wiper plate
- Load cells for weighing

FOOT PRINT:

